

1 mm to 25mm stroke
 $\leq 0.15\mu\text{m}$ repeatability
 $\leq 0.5\%$ linearity



High Precision HBT probe

DP series

User's Guide

The contents of this manual could be different and it can be changed without notice.
Please use this good after reading the manual thoroughly.

Product features & composition

1. Features



2. Connection

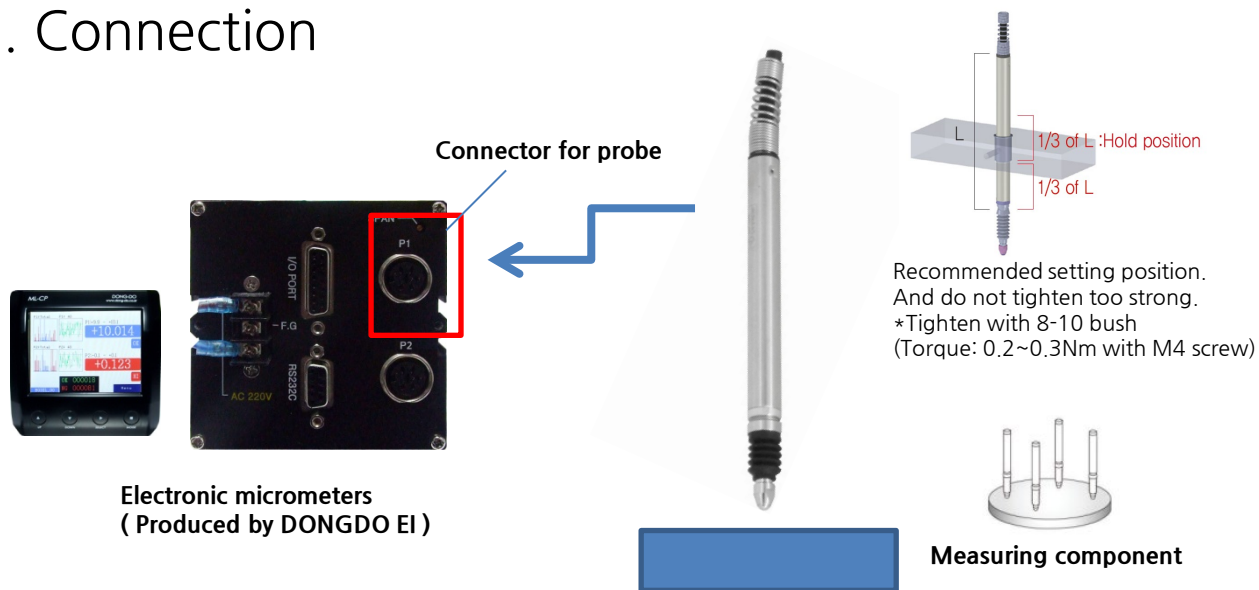

*Probes are always used with Electronic micrometers.
Elec. Micrometers converts the probe signal to the real value.

Used Area

3. Where to use

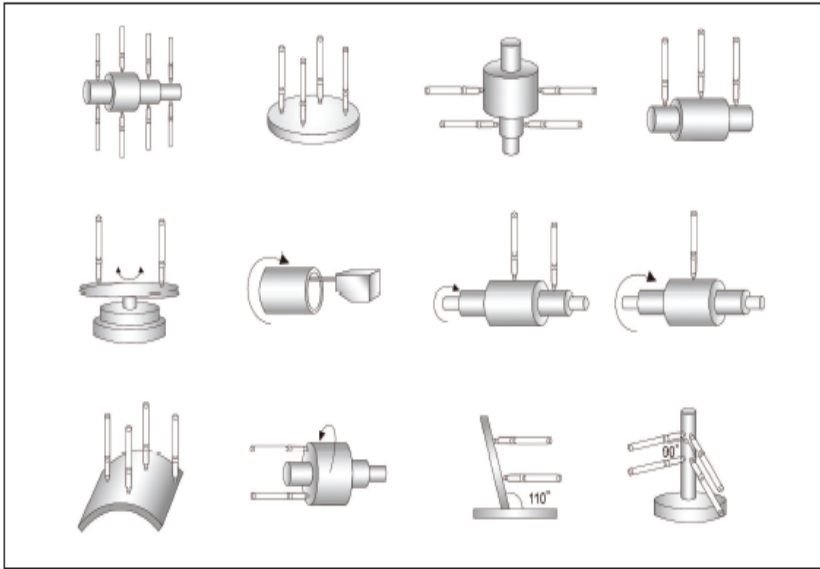

Probes are used to measure height, flatness, diameters, runout, angles, etc. The values are calculated in electronic micrometers.

4. Repeatability & linearity



1mm to 25mm stroke
Under 0.15um repeatability
0.2~0.5% linearity(Depends on the model)

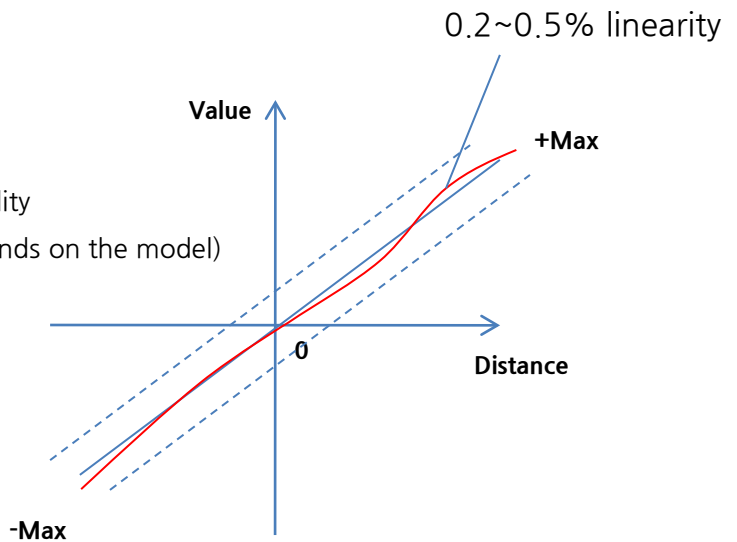

Specification

ITEM	DP-S1x	DP-S2x	DP-S4x	DP-10x	DP-15x	DP-25
Measuring range	±0.5mm	±1.0mm	±2.0mm	±5.0mm	±7.5mm	±12.5mm
Repeatability	≤0.15μm	≤0.15μm	≤0.15μm	≤0.4μm	≤0.5μm	≤0.5μm
Linearity error(FR)	≤0.2%	≤0.2%	≤0.5%	≤0.5%	≤0.45% at ±5.5mm	≤0.25% at ±8mm
Measuring Force(±25% at electrical zero position)	48g (0.5N)	48g (0.5N)	4~90g (0.04~0.9N)	30~80g (0.3~0.8N)	30~80g (0.3~0.8N)	180g (1.8N)
External Diameter	Ø8mm					Ø15mm
Operating Temp.	0~50°C					
Calibration Frequency(kHz) with 1.5V(rms)	13					16

The letter 'x' after the model name is an optional part and is filled with other characters such as blank, V, A, etc.

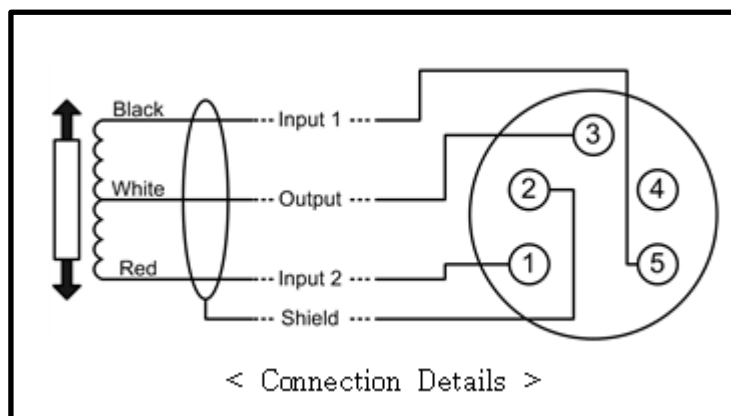

Caution

1. DP series HBT probes are used with electronic micrometers made in DONGDO EI CO., LTD. If it is used with others' amps, please check with the technical person.
2. Probes are very sensitive product which can measure in micrometer scale. So, should be used in a stable condition of temperature, humidity, vibration.
3. Probes are weak at an impact. Please control soft when it is installed on your system. And recommended to use $\varnothing 8-10$ bush which is supplied with all probes.
4. No magnet should be around probes. It will be a cause of probe damage.
5. All of probes has one year warranty.
6. No warranty when the damages are from users fault.
7. Over 50 million measuring cycles are the normal life. But it's totally related with the conditions to use.